



Dongguan Zhiding Electronics Technology Co., LTD

No. 8, Yinling Industry Zone, Xiaqiao, Dongcheng District,

Dongguan, Guangdong, China

Tel:86-0769-22665151 Fax:86-0769-22665155 Contact: Elsa Xiao Email: sales@zhidingled.com

High Power LED 5mm 0.5W

0.5W 40 degree angle dip diode led 5mm full colors led with heat sink

Basic information:

color:5mm full colors

Lens Color: water clear

View Angle:40 Angle

5mm 0.5W Round LED

package included: 1000pcs per bag

Features:

1. Chip Material: AllnGaP
2. Lens Color: Water Clear
3. Source Color: red/orange/yellow/blue/green/purple/white
4. Pb free.
5. The product itself will remain within RoHS compliant version.

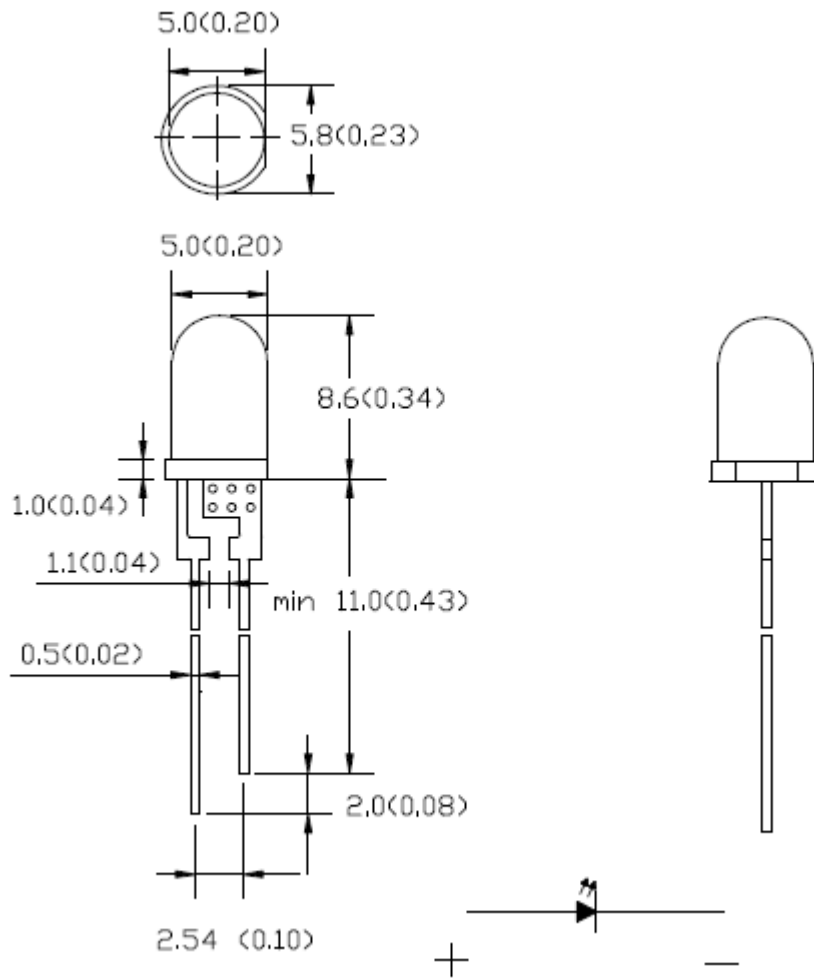

Notes:

1. All dimensions are in millimeters.
2. The height of flange must be less than 1.0mm.
3. Without special declared, the tolerance is ± 0.25 mm.

OEM ODM

HIGH QUALITY LED LIGHT

WE FOCUS ON THE BEST LED LIGHTS



More energy saving



High brightness



Durable



High-quality materials

PRODUCT PRESENTATION

5mm 0.5W LED Technical Datasheet

Color	Wavelength / Color Temperature	Current	Brightness	Viewing Angle
Red	620-630nm	150mA	10000-20000mcd	40
Orange	600-610nm	150mA	20000-40000mcd	40
Yellow	580-590nm	150mA	20000-40000mcd	40
Green	520-530nm	150mA	30000-60000mcd	40
Blue	465-475nm	150mA	10000-20000mcd	40
Purple	380-390nm	150mA	100-300mcd	40
White	3000K / 6000K / 9000K	150mA	50000-100000mcd	40

Application

Portable (flashlight, bicycle)

Uplighters / Downlighters

Decorative/Entertainment (stage light)

Bollards/Security/Garden

Indoor/Outdoor Commercial and Residential Architectural

Automotive Ext (Stop-Tail-Turn, CHMSL, Width Lamp)

APPLICATIONS

APPLICATION SCENARIOS:

Corridor, factory floor, warehouse, swimming pool, parking lot, tunnel, pedestrian bridge, subway station



RELATED PRODUCTS



5mm 0.5W LED



10mm 0.5W LED



SMD 2835 LED



SMD 3014 LED



SMD 3528 LED

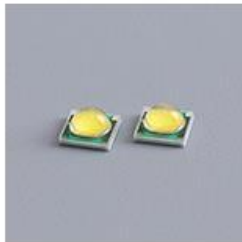

SMD 3535 LED



SMD 5050 LED



SMD 5730 LED

WHY CHOOSE US



Customized design is available, OEM and ODM are welcomed.



We have best production capability, best quality control, best service.



Reply your inquiry in 24 working hours.



Customized design is available, OEM and ODM are welcomed

CERTIFICATION



ABOUT US

Dongguan Zhiding Electronics Technology Co., LTD is a high-tech enterprise specialized in manufacturing, designing and selling high quality LED lighting and LED related products. Zhaoqing Factory has more than 1000 employees, including more than 80 technicians focused on research and development.

We have advanced testing equipment, can be "normal temperature continuous light life test", "high temperature and high humidity cycle test", "cold and hot shock cycle test" and "high and low temperature storage test", "high and low temperature continuous light test", "salt spray test" and reliability test, for all kinds of product reliability test of periodic on a regular basis, provides the high quality for our product quality assurance.



COOPERATIVE CLIENT

F&C[®]

SUGA[®]

OPT[®]
Machine Vision

USI[®]
Realizing IDEAS Together

mega
cell^{line}

UCHI

BlueSky

TOPBAND

BiROD

vtech[®]

SHIPPING

- SHIPPING**
- 1.FedEx/DHL/UPS/TNT for samples, Door-to-Door
 - 2.By Air or by Sea for batch goods, for FCL; Airport/ Port receiving
 - 3.Customers specifying freight forwarders or negotiable shipping methods
 - 4.Delivery Time: 3-7 days for samples; 5-25 days for batch goods



LED composition analysis

The structure of the dip diode LED consists of five materials: **bracket, silver paste, wafer, gold wire, and epoxy resin.**

FAQ:

Q1. How can you ensure your products quality?

A1. We start the quality control from the design stage. We can almost do every step in house and have professional QC and test equipment to ensure the quality.

Q2. What will be the best price terms?

A2. Normally price term is FOB.

Q3. How much will the express delivery cost?

A3. The shipping discount are different because of different weight, volume and destination. We will choose the cheapest and safest way according to your detailed requirement. For the exact cost, please contact us freely.

Q4. What information shall we offer you for a quotation?

A4. The shape of LED (prefer to show us pictures), wavelength, Emitting distance, viewing angle, voltage, usage, demand quantity (different order quantity different price).

Our Service

Your inquiry for our products or prices will be replied in 24 hours.

We offer the OEM and ODM service.

Protection of your sales area, ideas of design and all your private information.

We guarantee both quality and service regardless of your big or small order.

Advanced equipment and good materials: ASM machine, good chips and epoxy resin.

Most of the regular items, we are stocked, so we have an advantage in the delivery period. In the absence of inventory, we will arrange production as soon as possible according to customer needs. Providing quality service to customers is the basic premise of our sales. Welcome to inquire about our products!

WELCOME TO CONTACT US>>>>WWW.ZHIDINGLED.COM



Oversea Sales Manager
Elsa Xiao
E-mail:sales@zhidingled.com
Skype: elsa.xiao0418
Mobile: 86-13412570091
WhatsApp: 86-13412570091
Tel: 86-769-22665151
Fax:86-769-22665155